



## D4.5: prototype cars



Project acronym: I'CityForAll

Project name: Age Sensitive ICT Systems for Intelligible City For All

Strategic objective: Socio-acusis ICT solutions for a better social well-being of Ederly People

Project Duration: July, 1st 2012 – Dec, 31th 2015 (42 months)

Co-ordinator: CEA: Commissariat à l'Energie Atomique et aux Energies Alternatives

Partners: UPD: Université Paris Descartes  
 ENEA: Agenzia Nazionale per le Nuove tecnologie, l'EnergiA e lo sviluppo economico sostenibile  
 TUM: Technische Universität München  
 CRF: Centro Ricerche FIAT  
 CENTICH: Centre d'Expertise National des Technologies de l'Information et de la Communication pour l'autonomie  
 Active Audio

### D4.5

Version: 1.00  
 Delivery Date: M40  
 Due Date: M36  
 Task: 4.4  
 Leader: CRF  
 Authors: Giorgio Irato, Silvio Demarino  
 Dissemination status: RE

This project is co-funded by the Ambient Assisted Living (AAL) Joint program, by the German BMBF, by the Agence Nationale de la Recherche – ANR, by Caisse Nationale de la Solidarité pour l'Autonomie – CNSA, by the Ministero dell'Istruzione dell'Università e della Ricerca – MIUR, and by Federal Office for Professional Education and Technology OPET

**Once completed please e-mail to WP leader with a copy to**

sylvie.ghalila@cea.fr

D4.5	Executive Summary
This document describes the design/implementation of the Man-Machine Communication architecture for the demonstration prototypes of equipped cars (in lab and field versions)	
Keywords: HMI, audio HMI, visual HMI, pre-compensation, gain control, auralisation	

<b>Dissemination Level of this deliverable (Source: I'CityForAll Technical Annex p22-23)</b>	
RE	Restricted
<b>Nature of this deliverable (Source: I'CityForAll Technical Annex p22-23)</b>	
R	Report

Due date of deliverable	M36
Actual submission date	M40
Evidence of delivery	M40

Date	Version	Reviewer	Recommendations

Authorisation			
No.	Action	Company/Name	Date
1	Prepared	CRF	
2	Approved	CRF	
3	Released	CRF	M

**Disclaimer:** The information in this document is subject to change without notice. Company or product names mentioned in this document may be trademarks or registered trademarks of their respective companies.

## Table of contents

1. Introduction . . . . .	p.4
2. Layout description . . . . .	p.4
2.1. Laboratory prototype layout . . . . .	p.4
2.1.1. System overview . . . . .	p.5
2.1.2. The control tablet. . . . .	p.7
2.1.2.1. WIFI connection (mini router). . . . .	p.7
2.1.2.2. Wired connection to keypad. . . . .	p.8
2.1.2.3. (internal data-logging) . . . . .	p.8
2.1.3. External audio system (sirens). . . . .	p.8
2.1.3.1. Coupled PCs: external audio PC (the PC receives IP from the control tablet and sends signals from database to amplification chain). . . . .	p.9
2.1.3.2. 2 amplifiers.. . . .	p.9
2.1.3.3. Custom electronics switch-box . . . . .	p.10
2.1.3.4. 4 external loudspeakers . . . . .	p.11
2.1.4. Internal audio systems (background noise and audio alerts). . . . .	p.11
2.1.4.1. The noise and audio signals database. . . . .	p.11
2.1.4.2. Internal amplification chain: from the database to the switchbox and transducers. . . . .	p.12
2.1.4.3. Background noise simulation (Acoustic Shakers). . . . .	p.13
2.1.4.4. Internal audio system (audio HMI) . . . . .	p.13
2.1.5. The Visual HMI tablet. . . . .	p.14
2.1.5.1. Database of images . . . . .	p.14
2.2. Demonstrator (Equipped car) prototype layout . . . . .	p.15
2.2.1. System overview . . . . .	p.16
2.2.2. Microphone array and internal microphone . . . . .	p.17
2.2.3. Sound card (as IP from array). . . . .	p.18
2.2.4. Control PC (with algorithms for detection, angular localization, HMI sound sample selection, pre-compensation, ACG, control of the amplification chain). . . . .	p.19
2.2.5. Custom amplification box. . . . .	p.19
2.2.6. Additional loudspeakers . . . . .	p.20
3. Conclusions . . . . .	p.22
List of figures . . . . .	p.23

## Abbreviations

ACG Automatic Gain Control

ADAS Advanced Driver Assistance System

DOA Direction Of Arrival

GUI Graphical User Interface

HMI Human Machine Interaction

OE Original Equipment

SNR Signal to Noise Ratio

DAW Digital Audio Workstation (SW module for audio card control)

## 1. Introduction

The layout of the Man-Machine Communication architecture for the experimental / demonstration prototypes of 2 cars equipped with experimental systems, for enhancing the user's capability of timely detecting and localizing approaching emergency vehicles by means of audio and visual signals, is described.

## 2. Layout description

Two layouts are described. One concerns the mock-up used for the laboratory tests carried out at CRF site, the other is referred to the equipped car sent to Cerignola for the tests carried out on the CERCAT test track.

It has to be explicitly stated that the resulting final prototypes are intended as "proofs of concept" (and not as a pre-industrialisation prototypes), pointing towards interesting solutions to problems of man-machine communication.

### 2.1 Laboratory Prototype layout

The HMI layout is based on the combination of aural and visual signals.

Aural signals are reproduced by means of the standard loudspeakers installed for the stereo set of the car.

Visual signals are submitted to the users by means of the screen of a dedicated "tablet".

Visual and aural signals are appropriately synchronised.

The resulting layout must be connected to the sensory and processing modules that feed information about the signalled event (approaching emergency vehicle or other) in the equipped car. The information concerning the events to be signalled are *simulated* in the laboratory testing (under experimenter's control) in order to design an appropriate experimental plan, in which levels of the different control factors are correctly distributed for a meaningful statistical analysis.

---

### 2.1.1 Lab system overview

In order to get results covering the whole range of possible “real life” scenarios, experiments with jury panels take place in a lab, equipped in such a way that all possible control factors are taken into account and varied according to preliminary experimental planning (for more details about the experimental protocol see D1.6c “Protocol in-vivo for the assessment of car smart-loudspeaker prototype by users – laboratory test with jury panel (CRF contribution)”).

The abovementioned control factors can be summarized as follows:

- Angular position of the acoustic signal emitted by the approaching emergency vehicle (synthesized in 4 standard positions: front, back, left, right)
- Distance of the emergency vehicle (synthesized in 3 distance “groups”: safety distance, warning distance, danger distance, according to average situations and average subjective reaction times)
- In-car background noise (synthesized in 2 noise levels), possibly interacting with the perception of the aural information signal
- Typology of the audio information signal (spectro-temporal signature), potentially containing different amounts of useful information and thus showing different effectiveness in enhancing subjective response
- Localization information embedded in the interior audio information signal (“representation” of angular position and distance)
- Typology of the visual information signal (different images proposing the same information)
- Localization information embedded in the visual information signal (representation of angular position and distance)
- Interaction among the different perceptual stimuli (external emergency sound signal, in-car audio signal, visual signal)
- Effect of the different communication strategies (presbycusis pre-compensation, automatic gain control) in function of the hearing impairment of the subject (no impairment, slight impairment, strong impairment)

*[Two additional sessions have been added in the lab test, to verify audio/visual communication strategies when applied to interior HMI signals, not referred to external emergency vehicles : one based on LDW (Lane Departure Warning) signals, with only 2 possible DOA (left and right), one based on parking sensor signals, with 2 different possible DOA (front and back). The testing protocol is simplified but similar to the one concerning sirens.]*

All the scenarios that can be reproduced by the combinations of the control factors have been implemented in a lab equipped as follows (see fig. 1):

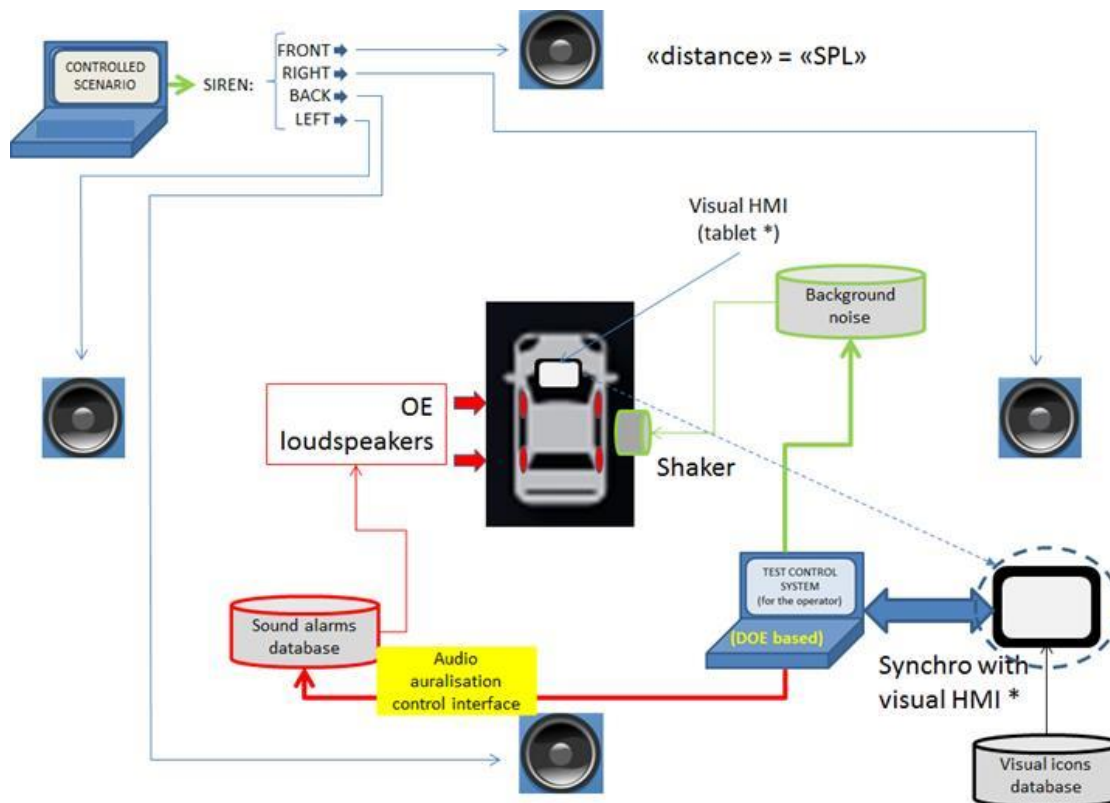

Fig. 1: lab layout overview

List of experimental layout items (in the lab test equipped car):

- A car standing still (thermal engine off) inside the lab (FIAT 500L)
- A computer-based system driving the acoustic and visual terminals (two coupled and synchronized PCs, one for managing the external siren sound, one for managing the internal noise and HMI sounds)
- The OE car stereo loudspeakers (for the auralisation of the audio HMI signals)
- Four external loudspeakers (for the simulation of an approaching emergency signal)
- Four acoustic shakers, fixed to the car body, for introducing olophonous background (masking) noise
- One tablet for the administration of the visual HMI signals (Asus Vivotab Note 8 M80TA)
- One PC-based system for data-logging (see details in the following)

The data-logging comprises:

- A secondary output sent by the control system (handled by the operator) at the activation of one "event" (set of stimuli constructing one of the possible scenarios), feeding the data-logger with the "start time" ( $t_0$ ). A variable delay (but fixed for every event) is given between  $t_0$  and the instant ( $t_s$ ) at which the audio information signal is presented
- A key-pad (handled by the test participant) to assess the choice of the perceived direction of arrival of a signal (DOA), simultaneously sending to the data-logger the "detection time" ( $t_d$ ).

- The difference  $\Delta t = (t_d - t_s)$  gives the estimation of the reaction time (the DOA is the first information processed by the test participant). Absence of detection input is computed as “missed detection” at the end of the submitted event (i.e.: when the audio file is over)
- A GUI (graphical user interface) handled by the experimenter to report verbal answers of the test person, concerning
    - o Perceived distance of the emergency vehicle (3 levels)
    - o Evaluations of the perceived quality of the audio HMI signal (concerning both meaning and pleasantness)
    - o Evaluation of the alerting power of the audio HMI signal
  - The data-logger will of course also record the configuration of all the control factors for each submitted event

### 2.1.2 the Control Tablet

The whole system is handled by the experimenter by means of the “Control Tablet” (Microsoft “Surface pro 3” tablet, programmed in HTML5), that sends commands to the audio and visual HMI devices and provides data-logging (on its own memory). The input of the lab apparatus starts with a text file, containing the information about all the generated events, according to an experimental



plan (in which the individual sequences are randomised for each participant to the subjective testing campaign). The text file is read by the “core” control software (running on the tablet used by the experimenter).

The experimenter selects the randomisation of events corresponding to each individual participant and inputs all data-logging (except for the “detection time”, that is input by the participant, see below)

Fig. 2: the Control Tablet

#### 2.1.2.1 WIFI connection (mini router)

The control tablet outputs data and commands to the HMI system by means of a WI-FI “web-socket” connection carried out via a Huawei mini-router. This connection engages 3 different addresses: one for the control tablet itself, one for the two PCs controlling audio events, one for the visual HMI monitor in front of the driver.



Fig. 3: the mini-router



### 2.1.2.2 Wired connection to keypad



The only external input received by the Control Tablet is coming from the keypad (USB-wired to the tablet) directly operated by the test participant. One of four buttons can be selected, sending information about perceived Direction Of Arrival of a sound signal (front, back, left, right) *and* the exact instant of detection. These data are stored in the internal data-logger.

Fig.4: the detection/DOA keypad

### 2.1.2.3 Internal data-logging

The remaining input is recorded by the experimenter by means of the touch-screen interface of the Control tablet. The recorded information concerns the answers given to a set of questions appearing on the screen, by means of check-boxes.

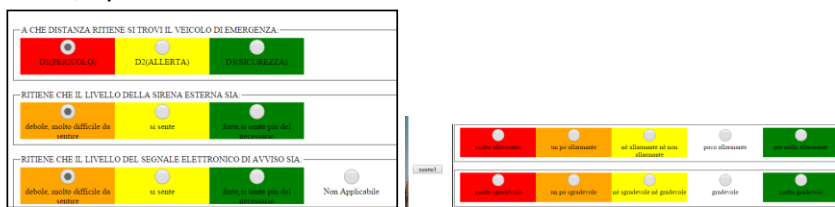

Fig. 5: checkbox scales

The GUI on the tablet also allows for the selection and direct activation of single sound samples to be submitted to the participant. The ID-name of the sample is recorded in the data-logger together with the related answers.



Fig. 6: audio files virtual control buttons

At the end of each experimental session, all the data concerning participant number, randomised sequence of events and related participant's responses are stored in an individual data file, ready for the following statistical analyses.

## 2.1.3 the External audio system (sirens simulation)

The information coming from the activation of a session, via the Control Tablet, activates the emission of the siren sound, coming from one of the 4 loudspeaker sets surrounding the test car (for reproducing DOA), at a defined loudness, variable through 3 levels (which are representative of the emergency vehicle distance). One of the 2 audio management PCs ("external audio PC") contains the whole database of audio signals reproducing the siren sounds at the different processing stages (variable levels and processing of simulated hearing impairment) and is programmed to send the

siren sound to the external loudspeakers through the correct channel switch. The connections are shown in fig. 7 and 8 below.



Fig. 7: Control Tablet connection with audio management system

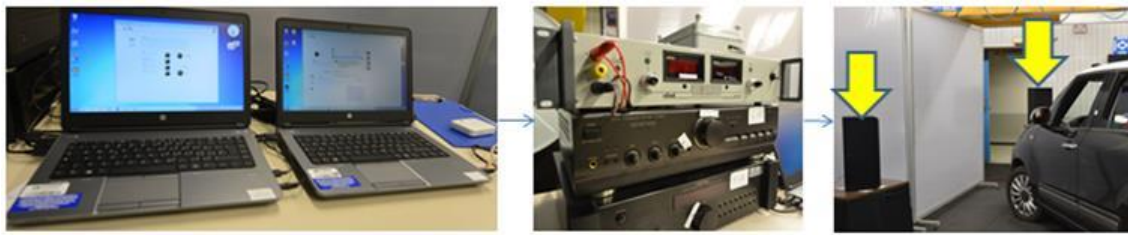

Fig. 8: audio management system connection with amplification and external loudspeakers

#### **2.1.3.1 Coupled PCs: external audio PC** (the PC receives IP from the control tablet and sends signals from database to the amplification chain)

The “n-th” event in the “m-th” randomised sequence (used for participant number m) corresponds to a particular angular position (“a”), distance (“d”), simulated presbycusis and related pre-compensation and ACG levels. These data produce the *selection* of the most appropriate siren sound sample (original level corresponding with distance “d” and filtering determined by selected pre-compensation and ACG processing) and its “*directional*” reproduction, by playing the sound on the proper loudspeakers in position “a” (by activating one of the 4 relay switches in the electronics box described in the following point 2.1.3.3).

#### **2.1.3.2 two amplifiers**

The (external) audio management PC is connected to the amplifiers (see fig. 8) that send the siren signal to the proper loudspeaker set. The regulation knobs of the amplifier have been regulated once for all after a calibration phase (measurements carried out at the driver’s ears position in the car).

**2.1.3.3 Custom electronics switch-box**

In order to have the signal sent at the desired loudspeakers, an electronics box has been designed and constructed, containing the relay switches needed to properly convey the audio signal.

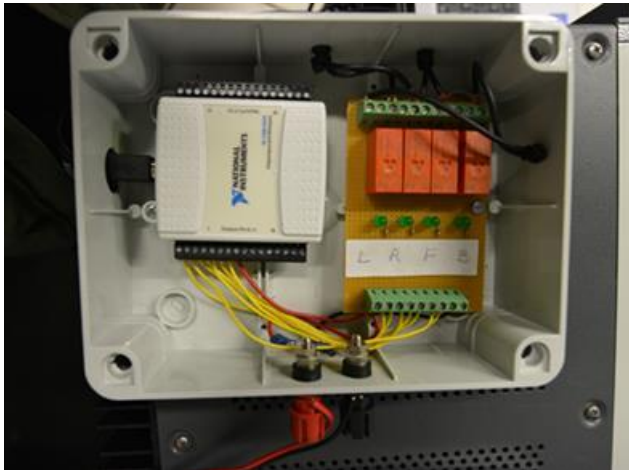

**Fig.9:** electronics box conveying siren sounds to the proper loudspeaker set (*the letters L, R, F, B visible inside the box stand for “Left, Right, Front, Back”*)

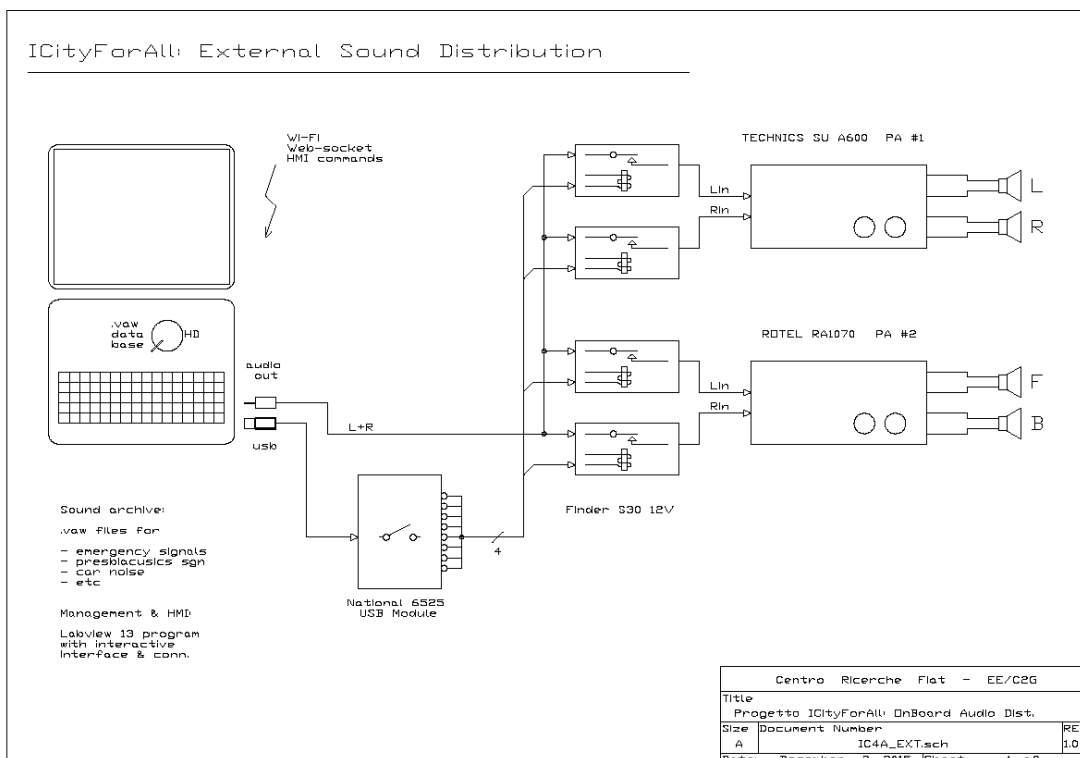

**Fig.10:** electrical scheme of the switchbox

This block scheme shows the connections between the two audio amplifiers, the External Audio Control PC and the loudspeakers.

Each sound file is on two identical tracks: the signal will be sent to the appropriate channel to obtain the desired DOA.

The level, used to simulate distance, is controlled directly by the selection of the proper audio output file, equalised at the requested level.

The position of the “volume” knobs on the amplifiers is regulated once and for all at the settings, in order to fix the “0 dB” reference level.

#### 2.1.3.4 four external loudspeakers boxes

The four external loudspeaker boxes are directly connected to the power outputs of each amplifier channel, the “L” and “R” channel of the first amplifier to the “front” and “back” loudspeakers, and the “L” and “R” of the second one to the effective “L” and “R” loudspeakers, as shown in the scheme in fig. 10 above.

The loudspeakers are effectively located on the front, at the back, on the left side and on the right side of the car, at the maximum distance permitted by the room dimensions, but respecting the front-back and left-right symmetry. The “DOA” (front, left, back and right) is then obtained.

### 2.1.4 The Internal Audio Systems (background noise and audio alerts)

#### 2.1.4.1 the noise and audio signals database

One of the two coupled PCs (“internal audio PC”) contains the whole database of background noise and internal HMI warning sounds.

Noise and HMI audio signals are coupled in each file, according to the randomization sequence, the background noise on one of the two channels of a stereo file, the acoustic warning on the other, starting with a pre-defined delay related to the start of the sound event (see examples in fig. 11)

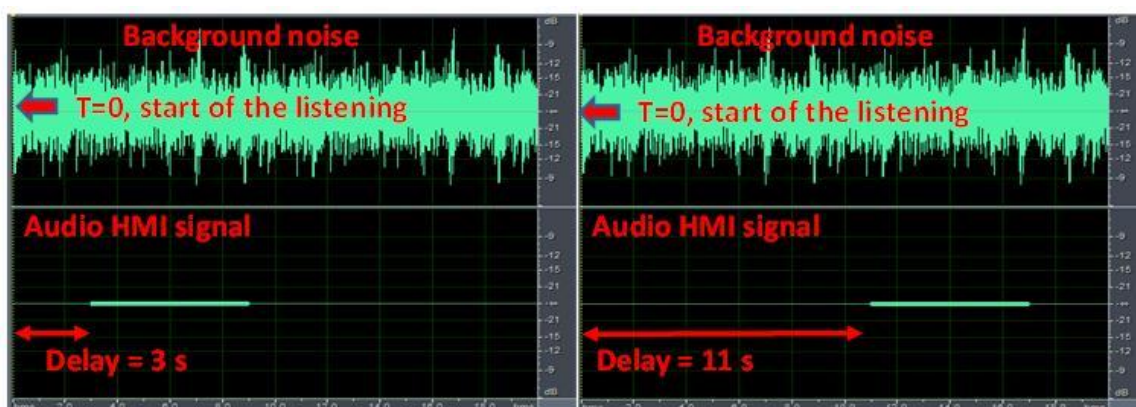

Fig.11: examples of stereo file containing background noise and delayed audio HMI

Noise recording and audio HMI are separately sent to a set of four acoustic shakers fixed on the roof of the car and to the four internal OE loudspeakers, respectively.

**2.1.4.2 Internal amplification chain: from the database to the switchbox and transducers**

Once the control tablet sends the activation command for the “event m” in the “randomization n”, the internal audio PC (synchronized with the external audio PC producing the corresponding siren sound) sends, through the amplification chain and the internal switchbox, the background noise signal to the four shakers and the HMI audio alert to the selected pair of internal OE loudspeakers. The connections are sketched in figure 12:

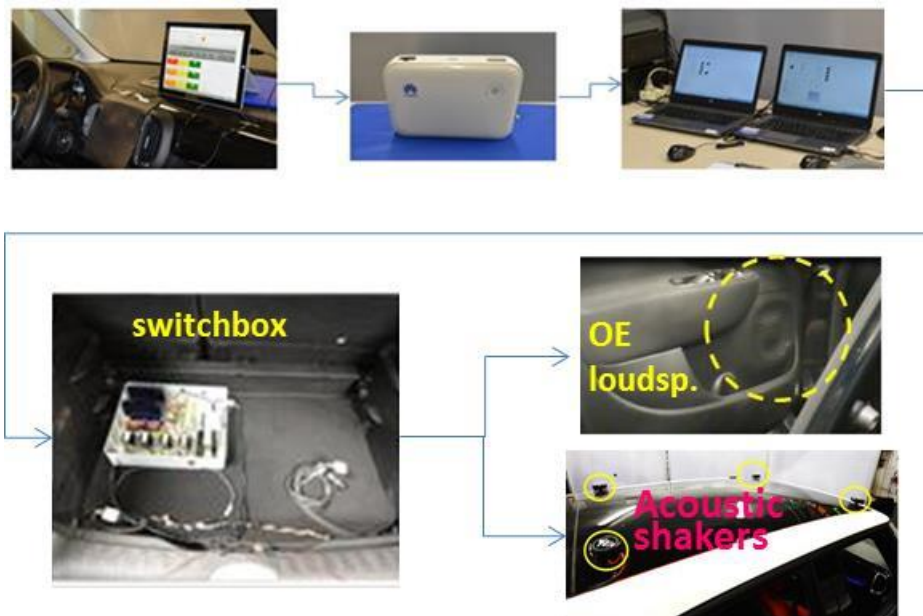

Fig.12: connections from control tablet to transducers

In the following figure 13 the electric diagram of the switchbox (receiving commands from the internal audio PC) is sketched.

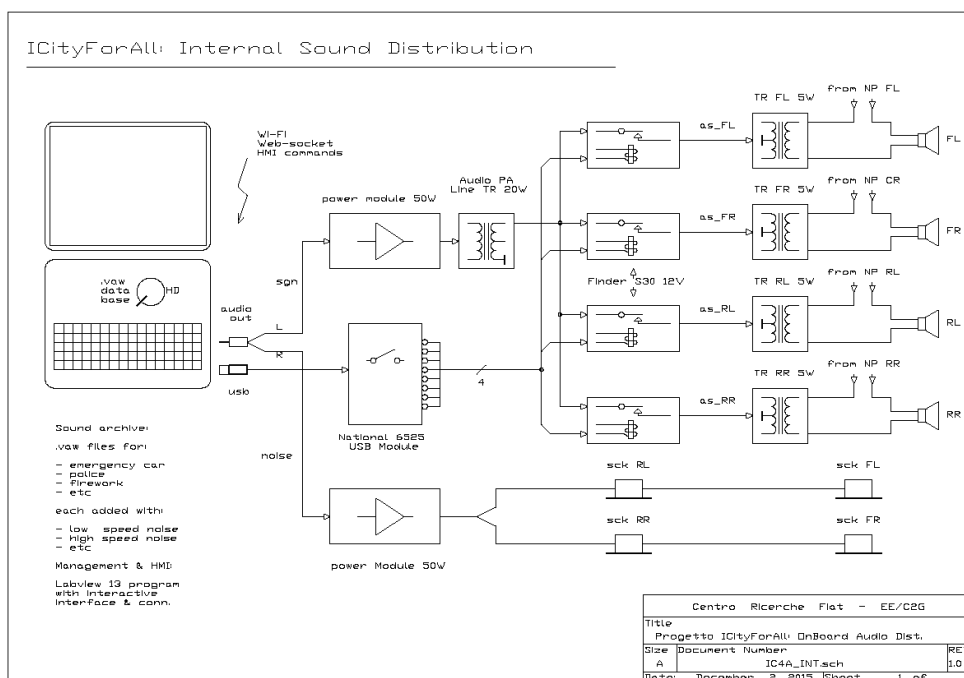

Fig.13: electric diagram of the internal switchbox

### 2.1.4.3 Background noise simulation (acoustic shakers)

The audio system manages the background noise samples, which are sent to four acoustic shakers fixed on the roof of the car (shown in fig. 12, bottom right), in order to get “olophonic” sound reproduction through the car body, in a way similar to what happens in a real car (with no special directional feature).

During the test 2 levels of **background noise** (simulating 2 normal levels of noise measured inside a car in moving conditions) are alternatively emitted inside the car compartment by means of the audio shakers fixed to the car body.

### 2.1.4.4 Internal audio system (audio HMI)

The OE electric connections between stereo set and internal loudspeakers have been by-passed and substituted by the wired connections to the custom switchbox, conveying the generated audio HMI signals to the selected pair of loudspeakers, according to the following scheme:

- both front (left and right) loudspeakers                      - for signal coming from the front
- both left (front and back) loudspeakers                      - for signal coming from the left
- both right (front and back) loudspeakers                      - for signal coming from the right
- both back (left and right) loudspeakers                      - for signal coming from behind

Accordingly, an **audio HMI signal** of varying features can be emitted inside the car, coming from a definite direction. The basic features of the implemented audio HMI signals (for the “siren-detector” test) are the following:

- 6 base signals are in the database, summarised as follows:
  - o Low frequency range (1 to 3 kHz) band-noise burst
  - o Mid-frequency range (3 to 8 kHz) band-noise burst
  - o Low frequency range bi-tonal square wave sequence (400 & 600 Hz)
  - o Mid-frequency range bi-tonal square wave sequence (1 & 1.5 kHz)
  - o Low frequency range sine wave (1.5 kHz), frequency modulated (by 500 Hz at modulation frequency 5 Hz)
  - o Mid-frequency range sine wave (3 kHz), frequency modulated (by 2000 Hz at modulation frequency 5 Hz)

All audio signals are stored on one channel of a stereo .wav file (the other channel containing the background noise).

All sounds are presented in 4 differently processed versions, according to a subdivision of the test population in **4 groups of “virtual” hearing impairment** (normal hearing: “IPO0”, + 3 levels of hearing loss: “IPO1”, “IPO2”, “IPO3”).



## 2.1.5 the visual HMI tablet

### 2.1.5.1 Database of images

The control tablet directly operates (through the WI-FI connection) on the visual HMI tablet monitor, placed in front of the driver (as shown in fig. 14).

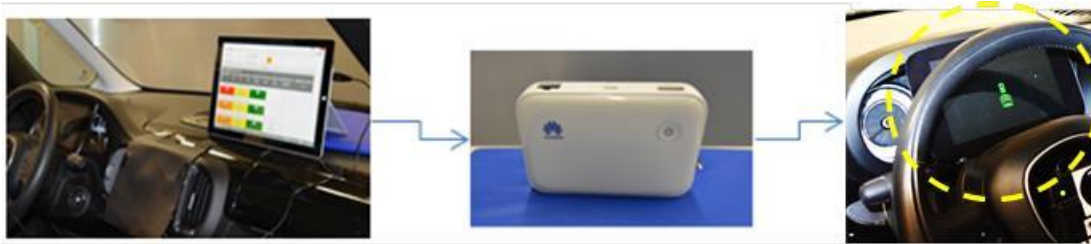

Fig.14: control tablet connection with visual information system

In the memory of the visual HMI tablet all possible alternative icons are stored as graphical files, shown on the screen according to the selection corresponding to the active event in the randomisation.

Three different graphical solution were devised and, for each of them, information is given about

- the DOA of the (simulated) incoming emergency vehicle (by positioning the drawing of the incoming signal around the image representing the ego-car)
- the estimated distance of the emergency vehicle (by means of the Green – Yellow – Red colour code, plus textual information)

In the following pictures 15 a. and b. some examples of the visual icons are given

a. Different graphical solutions:

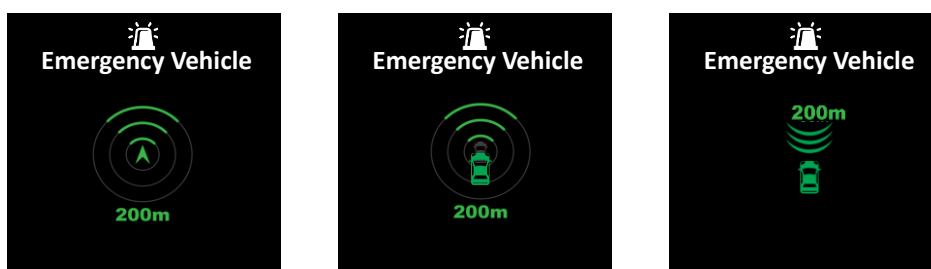

b. Different distances and directions



Figure 15: examples of visual icons

## 2.2 Demonstrator (equipped car) prototype layout

After the experimental campaign carried out with the experimental lab layout has given the information requested for choosing the optimal HMI configuration, the audio HMI system has been programmed with the final signals and adapted to the connection with the sensory and processing units (microphone array, localisation module, pre-compensation module, automatic gain control “ACG”) installed on the field-test equipped car, as sketched in fig. 16.

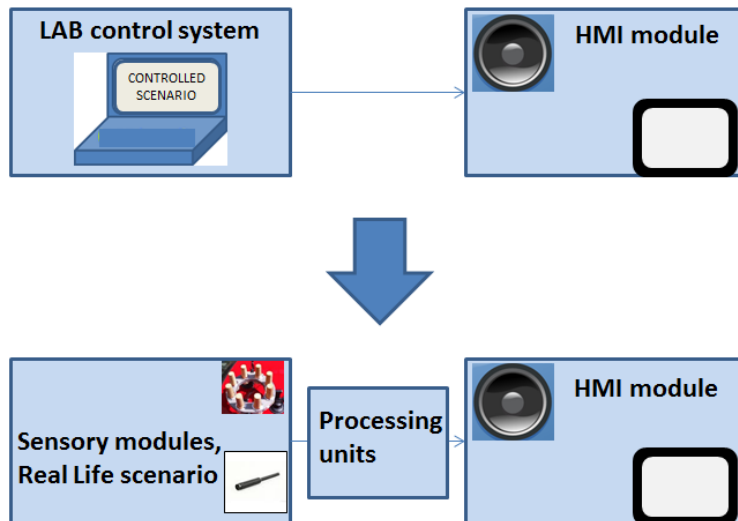

Fig.16: integration of the HMI module in the field prototype

The integration of the HMI units in the final prototype has implied the substitution of the laboratory hardware with suitable processing platforms and all related devices, programmed to turn information concerning the real life events into the control factors commanding the choice of the appropriate communication sequence (audio signals), instead of the situations fixed in the experimental plan used for the lab experiments. Data flow and relative interfaces are supplied by involved partners, taking into account the available Project’s specifications.

Two vehicles are involved in the field application, taking place on a test track: the equipped “demo” car (“ego-car”, FIAT Multipla) and an emergency vehicle (“em-car”) equipped with the emergency signal sound source (the “siren” – mod. SE 2 NDM by “SIRENA S.p.A.” - Italy).

Tests have been devised in which the ego-car moves around the emitting source, at known angular positions, on a test track without acoustic obstacles. Different cars are parked on the same test track together with the car equipped with the siren, in such a way that the participant cannot “visually” recognize the position of the emitting source.

Before all, the kind of processing of the acoustic levels (pre-compensations) for the demo prototype is assumed to be selected (after some trials) in advance for each user, in function of the depth of his/her hearing impairment. This choice is made available by means of some sort of 4-level control (like the “0” block in the sketch of fig. 17 below). From this moment on, the pre-compensation filter is chosen once and for all, for each individual user.

After this choice has been made, the system can start to work and the data-flow begins.



### 2.2.1 System overview

Overall “data-flow” layout of the final experimental and demo prototype is schematically sketched in fig. 17:

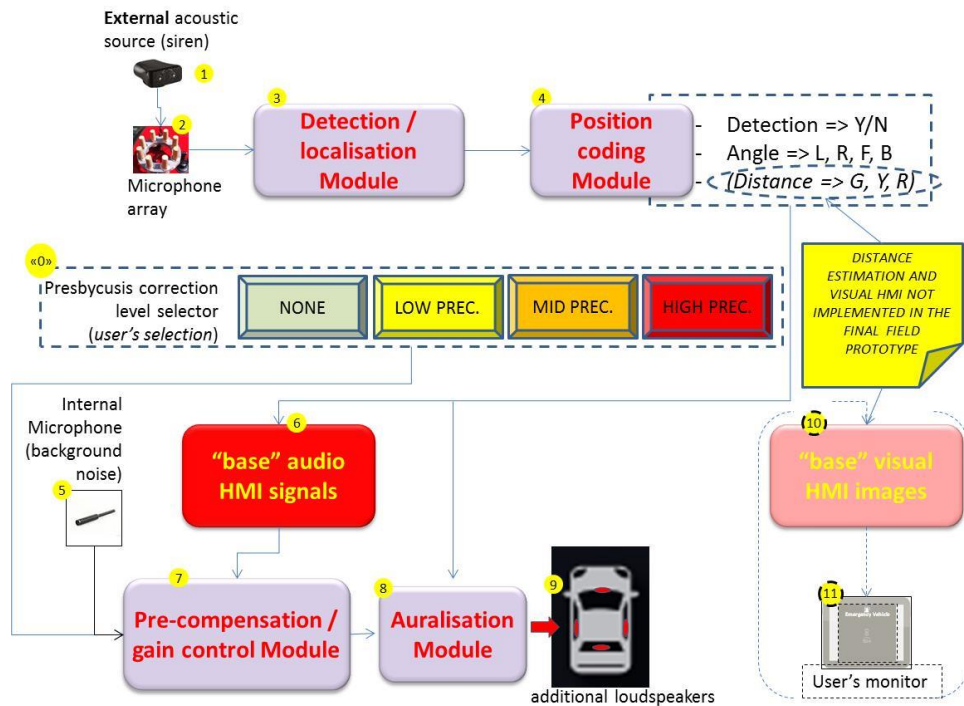

Fig. 17: schematic layout of the “field prototype” of car equipped with “siren-detector”

It has to be noted that in its final layout the system

- does not supply information about the distance of the emergency vehicle
- does not supply visual information

In the following picture 18 the scheme of the hardware set-up of the equipped ego-car is given:

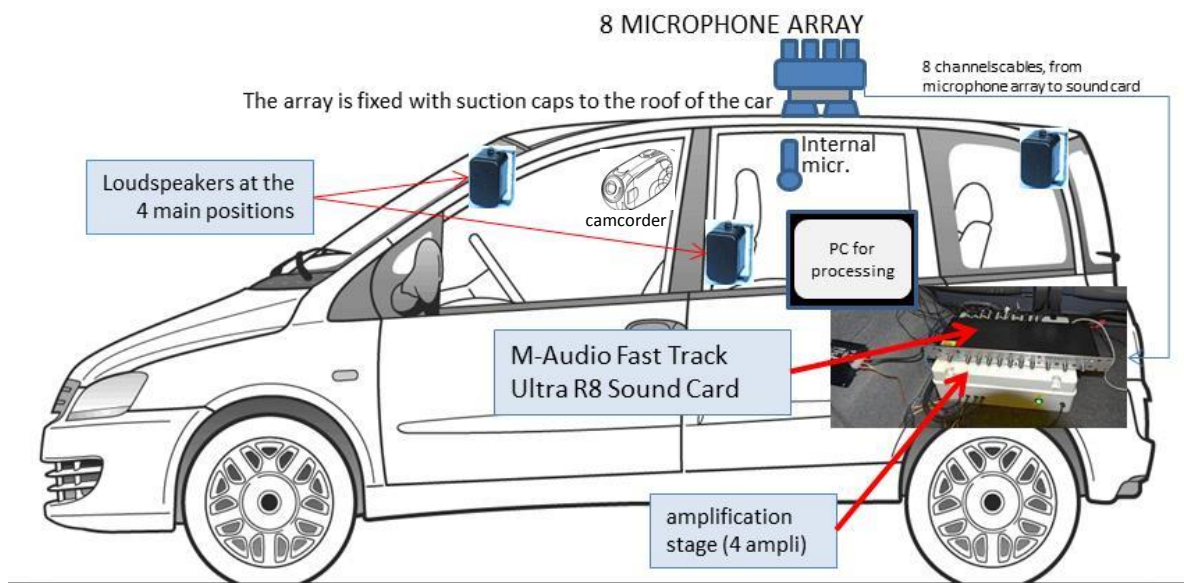

Fig.18: hardware layout of the equipped car

The experimental layout items (in the “field test” equipped car) are listed below:

- A car moving on the test CERCAT test track in Cerignola (FIAT Multipla)
- An external sensory module, consisting in an 8-microphone array with sintered metal weather protections (to sample external siren sound)
- An internal sensory module consisting in an omnidirectional microphone (to sample internal background noise)
- Four additional loudspeakers, mounted inside the car compartment at the four relevant directions (front, back, left, right)
- A Processing PC running the detection/localisation algorithms, the pre-compensation filtering and the Automatic Gain Control on the audio HMI signals, the DAW driving the sound card, and receiving additional input from the internal microphone
- An M-Audio Fast Track Ultra R8 sound card, receiving input from the microphone array and sending output to the amplification-loudspeakers chain
- A camcorder used for reaction time measurement, plus paper questionnaire about DOA
- Custom amplification box receiving input from the sound card, with four individual amplifiers sending audio signals to each additional loudspeaker

All HW inside the equipped car is powered by means of two internal 12V supplies, with the exception of the processing PC, which is working with its own battery (periodically re-charged).

## 2.2.2 Microphone array and internal microphone

The sensory module is consisting of (see fig. 19a and 19b)

- The 8 microphone array designed and constructed by EPFL (see a detailed description in D4.1 “System architecture, HW components, interfaces, test plan for system and components” and D4.3 “Microphone array prototype: use manual”), for sampling on a directional basis the sound of the external siren, connected to the 8 input slots of the M-Audio sound card
- An internal omnidirectional microphone fixed to the roof of the car (Lavalier RS 1000 $\Omega$  16mm) for sampling the interior background noise, directly connected to the mini-Jack plug of the processing PC

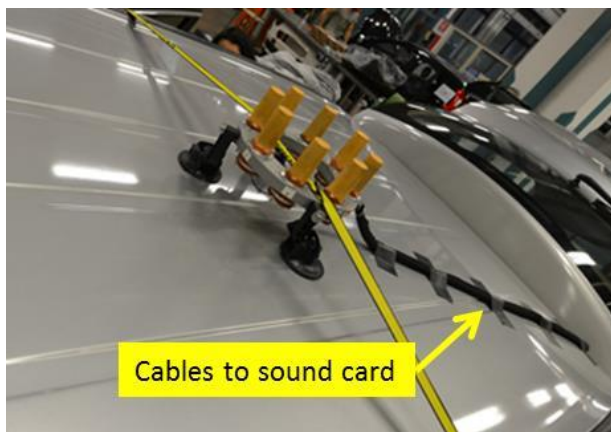

Fig 19a: 8-microphone array



Fig.19b : the internal omnidirectional microphone

### 2.2.3 Sound Card

The traffic of the sound signals (both IP and OP) is handled by means of the M-Audio Fast Track Ultra R8 sound card (see fig. 20).

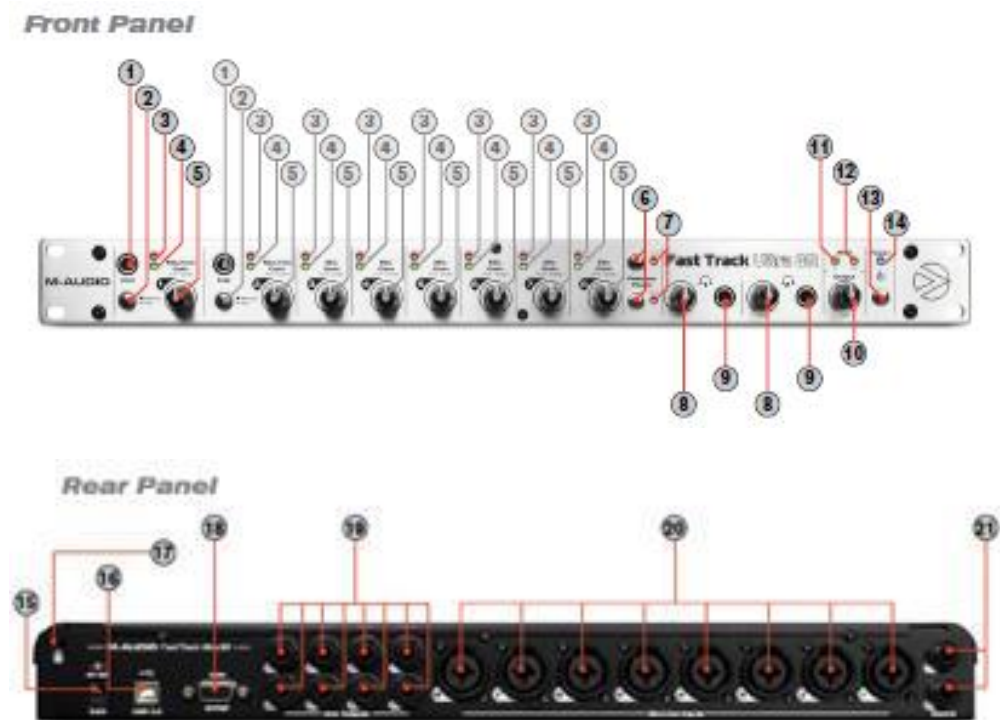

Fig.20: the M-Audio sound card (front and rear panel)

For a complete description of the sound card functions and architecture, see D4.1 “System architecture, HW components, interfaces, test plan for system and components” and “Fast Track Ultra 8R User Guide”.

## 2.2.4 control PC (algorithms for detection, angular localisation, HMI sound sample selection, pre-compensation, ACG, control of the amplification chain)

The control PC, operated by the experimenter during the test session, receives the external siren sound through the 8 input channels of the sound card, carries out the necessary detection and localisation operations, activates the sending (via USB connection) of the appropriate directional audio HMI signals, operates the pre-compensation filtering (in function of the selected level of hearing capacity of the participant, previously measured with an audiogram), receives direct input from the internal microphone, concerning the background noise level, and operates the corresponding Automatic Gain Control. Detection/localisation algorithms are described in D4.2 "Specification of signal processing algorithms" and D4.4 "Software documentation", audio processing algorithms are described in D2.4 "Software: 3 kinds of parametrized software, needed for WP3 and WP4" and D3.2 "Conception of digital filters for hearing loss compensation in cars". ...

The database of used audio HMI signals is stored inside the memory of the control PC. In the field test only two base signals have been used (a 3 to 8 kHz band-passed noise burst and a 1 to 1.5 kHz bitonal signal). The choice of reducing the number of signals was made for the sake of limiting the duration of each subjective test (not to deteriorate the participant's performance).

## 2.2.5 Custom amplification box

Inside the car and connected to the sound card output a custom amplification box is fixed inside the baggage compartment, sending signals, by activating the corresponding relay switch, to one of the additional internal loudspeakers. In the following picture 21 the scheme of the hardware set-up is given:

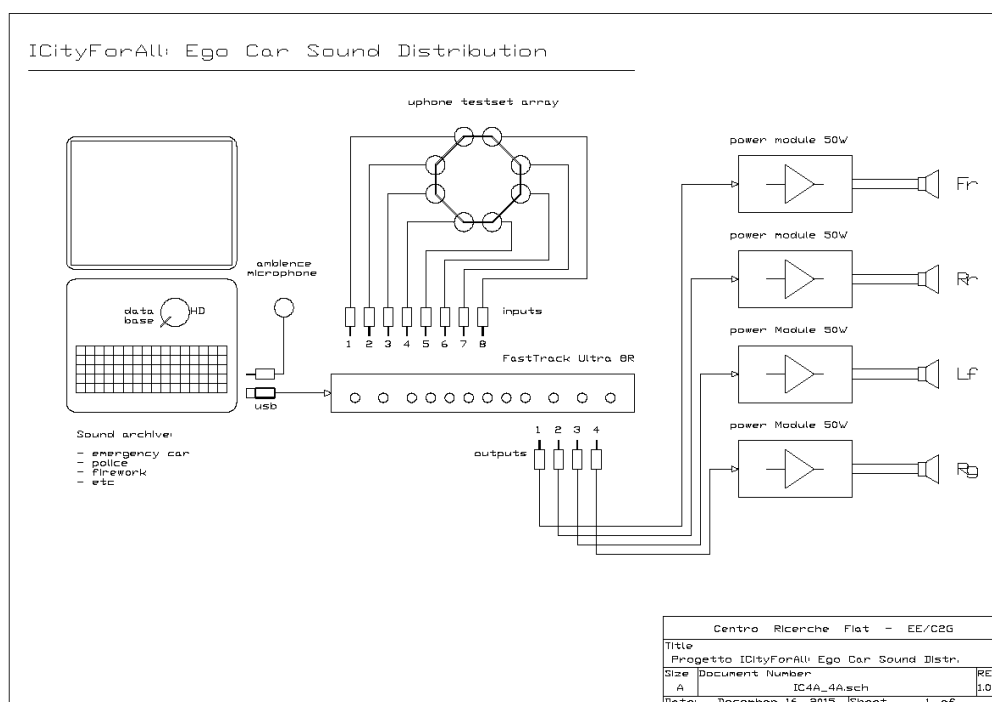

Fig.21: the scheme of the amplification box

the switchbox contains 4 separate audio power modules, one for each channel, each connected to one of the additional loudspeakers (see fig. 22)

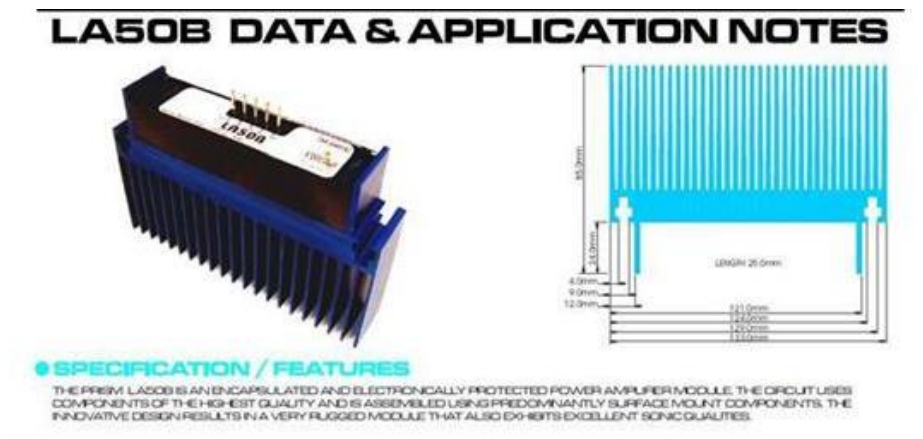

Fig.22: audio module used for the amplification box outputs

## 2.2.6 additional loudspeakers

The audio HMI signals are conveyed to the driver's ears by means of the four additional loudspeakers shown in fig. 23:



Fig.23: additional loudspeaker

---

Summarising (numbers of each item are referred to fig. 17):

- First, in the field test case, the “activating” input comes from the emission of the warning signal by the siren of an emergency vehicle (1).
- The acoustic input is captured by the microphone array (2) and turned into electrical signals, coded as an 8-channel audio input, through the sound card, to the detection and localisation unit (3). The levels of the 8 microphones are compared by applying the detection and localisation algorithms developed in the project, that:
  - o recognise and detect an emergency vehicle siren within the surrounding acoustic ambience
  - o analyse the relationship among the different microphone signals and produce an estimation of the angular position of the target source (the siren), with a given degree of precision and accuracy
- The position coding module (4) included in the detection/localisation system sends a command to the memory units (6) where the audio files are stored, to signal that a siren has been detected (detection value=Y) and HMI communication must be activated, so that an audio file is read and processed.
- Differently from the laboratory situation, background noise is an ecological event and its level must be monitored in real time. To this purpose a “supplementary” microphone (5) is added inside the ego car, estimating *in real time* the noise level in proximity of the driver’s head. The measured level is compared to an audibility and an annoyance threshold, so that the output audio HMI signal is emitted at appropriate volume.
- The sound signal activated in the previous steps is read on the storage unit and sent as electrical signal to the pre-compensation and gain control module (7). Here the signal is processed in real time according to the choice made with the selector (“0”, pre-compensation level, function of the hearing impairment) and the information supplied by the microphone measuring the background noise level for the gain control.
- This level regulation is carried out by the “ACG” (Automatic Gain Control) in module (7), developed in the project. It acts directly on the audio system volume, in real time, according to the [masking patterns](#) studied to this purpose
- The pre-compensated / gain-controlled audio signal is sent to the auralisation module (8) together with the command string specifying DOA angular quadrant, coming from the position coding module. The [auralisation](#) module deals separately with levels to be sent to (one of) the 4 OE internal loudspeakers (9), so that the final audio HMI signal is emitted coherently with the localisation information (the “virtual acoustic source” is located in the correct quadrant, relative to the driver’s head)
- Reaction time of the driver is measured by computing the time lapse recorded by means of a camcorder, while the subjective evaluation about DOA is recorded on a paper questionnaire managed by an experimenter.



### 3. Conclusions

This document describes the two experimental and demo prototypes designed and implemented for the I'City for All final activities.

The architectures are based on a system capable to detect and localise the emergency vehicle by means of an acoustic sensor (microphone array) and to communicate the related information to the user by means of audio (and possibly visual) HMI.

The HMI features are particularly oriented to facilitate improvements in the response of hearing impaired people (affected by presbycusis), but, coherently with the underlying intent of the project, it should prove useful "for all" (for normal hearing people, too).

So, different levels of audio signals processing are made available in order to fulfil the needs of people with different levels of hearing capabilities, and in the lab test different visual HMI features are tested in order to enhance the aural communication, with the final goal of improving ability of any user to react correctly in presence of incoming emergency vehicles.

The resulting laboratory and field layouts can prove useful also as testing benches for quality and effectiveness evaluations of HMI solutions for a number of different functions.

The final demonstrator prototype set up on the basis of the results of the lab experiments should serve as a "proof of concept" and an evaluation of the possible improvements that can be produced by means of the application of the developed solutions.

## List of figures:

[Fig. 1: lab layout overview ... p.6](#)

[Fig. 2: the Control Tablet ... p.7](#)

[Fig. 3: the mini-router ... p.7](#)

[Fig.4: the detection/DOA keypad ... p.8](#)

[Fig. 5: checkbox scales ... p.8](#)

[Fig. 6: audio files virtual control buttons ... p.8](#)

[Fig. 7: Control Tablet connection with audio management system ... p.9](#)

[Fig. 8: audio management system connection with amplification and external loudspeakers ... p.9](#)

[Fig.9: electronics box conveying siren sounds to the proper loudspeaker set ... p.10](#)

[Fig.10: electrical scheme of the switchbox ... p.10](#)

[Fig.11: examples of stereo file containing background noise and delayed audio HMI ... p.11](#)

[Fig.12: connections from control tablet to transducers ... p.12](#)

[Fig.13: electric diagram of the internal switchbox ... p.12](#)

[Fig.14: control tablet connection with visual information system ... p.14](#)

[Figure 15: examples of visual icons ... p.14](#)

[Fig.16: integration of the HMI module in the field prototype ... p.15](#)

[Fig. 17: schematic layout of the "field prototype" of car equipped with "siren-detector"... p.16](#)

[Fig.18: hardware layout of the equipped car ... p.16](#)

[Fig 19a: 8-microphone array ... p.17](#)

[Fig.19b : the internal omnidirectional microphone ... p.18](#)

[Fig.20: the M-Audio sound card \(front and rear panel\) ... p.18](#)

[Fig.21: the scheme of the amplification box ... p.19](#)

[Fig.22: audio module used for the amplification box outputs ... p.20](#)

[Fig.23: additional loudspeaker ... p.20](#)